

N-Vision Optics LLC

220 Reservoir Street, Suite 26, Needham, MA 02494
781-505-8360

OPERATOR'S MANUAL Thermal Imaging Weapon Sight HALO-XRF

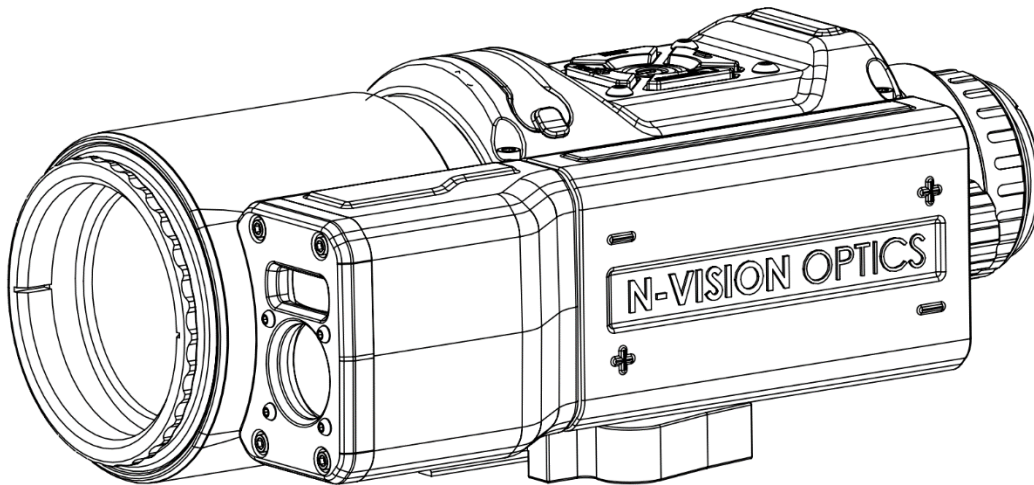

Revision 1.3 November 2022

**© 2022 Copyright N-Vision Optics LLC
All rights reserved**

TABLE OF CONTENTS

TABLE OF CONTENTS	1
LIST OF FIGURES	2
LIST OF TABLES.....	2
General Information	3
Scope	3
Safety Summary	3
FCC Compliance Statement	3
Warnings	3
Unit Overview	5
Features	5
HALO-XRF Components and Controls.....	7
Standard Kit.....	8
Operation	8
Installing Batteries	8
Turning the HALO-XRF On and Off	9
IMPORTANT: Thermal Calibration.....	10
Focusing.....	10
Diopter Adjustment	10
Mounting the HALO-XRF on a Weapon	11
Operating Modes and Menus.....	13
HALO-XRF Control Buttons	14
HALO-XRF Screen Icons.....	17
Table 3 below provides descriptions of icons that can be present in the Normal Mode.	17
Normal Mode Description	17
Taking Photos / Video Recording / Video Streaming.....	17
Selecting Polarity.....	18
Digital Zoom	18
LRF.....	18
Reset to Factory Settings.....	19
Menu Mode Description	19
Navigation in Menu Mode	19
Main Menu.....	20
Display Menu	22
System Settings Menu.....	23
Reticle Menu.....	24
Camera Menu.....	25
Connect to PC	26
LRF.....	26
Zero.....	27
Zeroing Mode Description	27
Zeroing Procedure	27
TH Zero	28
WiFi Download / Deletion of Files	28
Maintenance Instructions	29
Preparing for Maintenance.....	29
Cleaning the HALO-XRF.....	29
Electrical Interface	31
Troubleshooting	31

LIST OF FIGURES

Figure 1. HALO-XRF Thermal Weapon Sight.....	5
Figure 2. HALO-XRF and Control Buttons.....	7
Figure 3. HALO-XRF with Removed Battery Compartment Cover.....	9
Figure 4. Unlocking Picatinny Mount	11
Figure 5. Moving Lever to the Fully Unlocked Position	11
Figure 6. Tension Adjustment Nut.....	12
Figure 7. Adjusting Tension of the Mount.....	12
Figure 8. HALO-XRF Control Buttons	14

LIST OF TABLES

Table 1. Key Specifications	6
Table 2. The Functionality of Buttons in Different Modes	14
Table 3. HALO-XRF Icons.....	17
Table 4. Troubleshooting Instructions	31

General Information

You must familiarize yourself with the entire manual before operating the equipment. Read the complete manual and follow all **WARNINGS** and **NOTES**. Study this manual carefully and understand all related safety precautions.

Scope

This manual provides the user with information about operations, maintenance, and troubleshooting of the advanced thermal imaging weapon sight, HALO-XRF.

Safety Summary

- HALO-XRF is a precision electro-optical instrument that must be handled carefully at all times to prevent damage.
- To protect the HALO-XRF from unnecessary damage and performance degradation, never point the unit at extremely hot objects, such as the bright sun or hot, burning fire.
- Do not activate the LRF while aiming at the human eye or while looking in the transmitting (rectangular shaped) lens of the LRF.
- Do not scratch the lens surface.
- Be careful not to touch the lens surface. To remove contamination or fingerprints, carefully use lens cleaning paper on the objective lens's surface.
- Do not carry batteries in pockets containing metal objects such as keys, coins, sharp tools, etc. Those objects can damage batteries and short-circuit them. Shorted batteries may become very hot.
- Only use rechargeable 18650 batteries approved by N-Vision Optics and NEVER use two CR123 batteries instead of 18650.

FCC Compliance Statement

This device complies with part 15 of FCC Rules and Industry Canada's license-exempt RSSs. Operation is subject to the following two conditions: (1) this device may not cause harmful interference, and (2) this device must accept any interference received, including interference that may cause undesired operation.

Warnings

THE THERMAL IMAGING SENSOR USED WITHIN THE HALO-XRF IS VERY SENSITIVE TO EXPOSURE TO EXTREMELY HIGH LEVELS OF RADIANT FLUX (HEAT).

NEVER EXPOSE THE HALO-XRF, EITHER TURNED ON OR NOT, DIRECTLY TO THE SUN OR ANY OTHER SOURCE OF HEAT THAT THE HUMAN EYE CANNOT TOLERATE. EXPOSURE TO A HIGH LEVEL OF RADIATION WILL DAMAGE THE HALO-XRF SENSOR.

KEEP THE OBJECTIVE LENS COVER CLOSED OR ON AT ALL TIMES WHEN THE HALO-XRF IS NOT IN USE.

INADVERTENT SUN DAMAGE IS NOT CONSIDERED A DEFECT IN MATERIAL OR WORKMANSHIP AND IS NOT COVERED UNDER THE PRODUCT WARRANTY.

*** **NEVER** ATTEMPT TO POWER UP THE HALO-XRF USING TWO CR123 BATTERIES (RECHARGEABLE OR NON-RECHARGEABLE) INSTEAD OF ONE OR BOTH 18650 BATTERIES. THE CAUSED DAMAGE **WILL NOT** BE COVERED UNDER WARRANTY.

DO NOT USE RECHARGEABLE 18650 BATTERIES THAT N-VISION OPTICS DOES NOT APPROVE. THE USE OF UNAPPROVED RECHARGEABLE BATTERIES MAY LEAD TO DAMAGE TO HALO-XRF AND PRESENT A SAFETY RISK.

Unit Overview

Figure 1 below shows the HALO-XRF thermal imaging weapon sight.

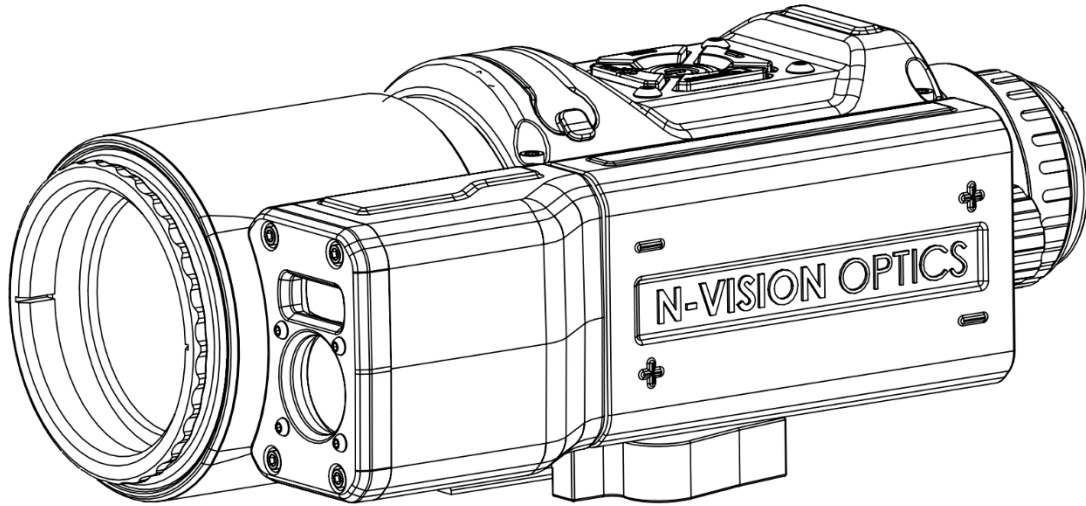

Figure 1. HALO-XRF Thermal Weapon Sight

Features

- Observation regardless of the light level
- Eight user-selectable reticles
- Electronic windage and elevation adjustments
- Fixed focus athermalized objective lens
- Black hot/white hot, black/white edge detect polarity selections
- Digital 2x, 4x, and 8x zoom
- Internal video recording
- WiFi streaming
- Integrated Laser Rangefinder (LRF)
- High resolution throughout the entire field of view
- Standard MIL-STD-1913 (Picatinny) rail mounting system
- Nitrogen purged to prevent internal fogging and extend the service life
- State of the art impact-resistant engineered plastics housing

Key Specifications

Key specifications are presented below in Table 1. Additional model-specific characteristics can be found on product specification sheets or by contacting N-Vision Optics.

Table 1. Key Specifications

	HALO-XRF (50 mm)
Sensor type	Uncooled vanadium oxide (VOx) microbolometer
Detector resolution	640 x 480
Spectral response, μm	7.5 - 13.5
Detector pitch, μm	12
Refresh rate, Hz	60
Reticles	8 user-selectable types
Objective lens	Germanium 50 mm F1.1
FOV, degree	8.7(H) x 6.6(V); 10.9 (diagonal)
Focus	Fixed
Detection, man-size target, typical, yards	2,020
Recognition, man-size target, typical, yards	726
Identification, man-size target, typical, yards	380
LRF Wavelength, nm	905
LRF Range, yards	10 to 1,000
LRF Accuracy, yards	± 1
Power, internal	Two 18650 rechargeable batteries
Power, external	USB, 5V
Display type	OLED, B&W
Display resolution	640 x 480
Diopter adjustment, diopters	-6 to +2
Size (L x W x H), in	8.9 x 4.1 x 3.4
Weight w/18650 batteries, oz	41.5
Surface finish	Dark
Environmental protection	IP67
Internal Memory	3.6 GB

HALO-XRF Components and Controls

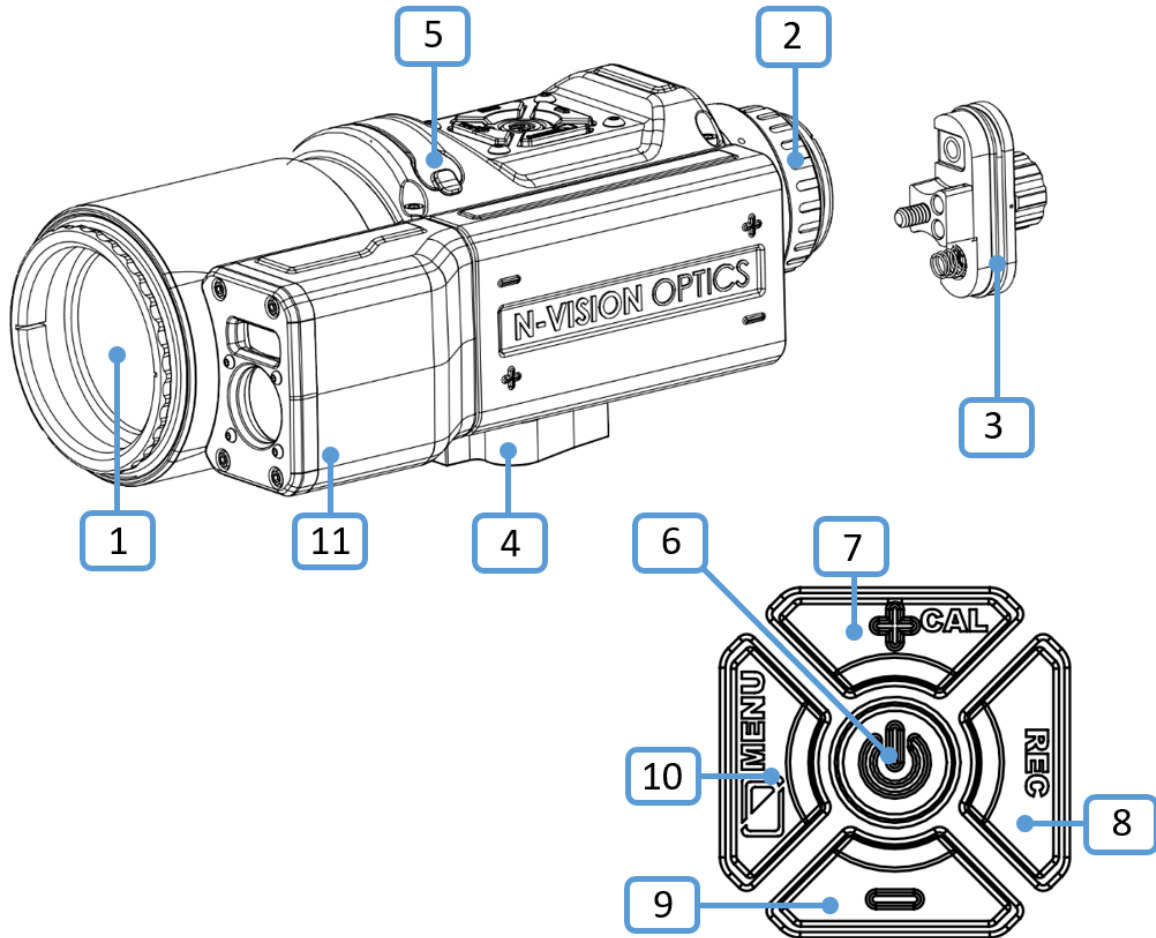

Figure 2. HALO-XRF and Control Buttons

Refer to Figure 2 to identify critical components and control buttons.

1. Objective Lens. The lens cover is not shown for clarity.
2. Ocular (eyepiece). Eyecup is not shown for clarity.
3. Battery Compartment Cover.
4. MIL-STD-1913 (Picatinny) Rail Mount
5. Electrical Connector (under dust cup)
6. **POWER / ZOOM** Button
7. **+ / CALIBRATION** Button
8. **RECORDING** Button
9. **LRF / - / RESET** Button
10. **POLARITY / MENU** Button
11. LRF Module

Standard Kit

Standard HALO-XRF kit includes unit, hard carrying/storage case, USB cable, lens-cleaning paper, quick reference guide, two 18650 rechargeable batteries, charger for 18650 batteries.

Operation

Refer to Figure 2 to identify critical components.

Installing Batteries

WARNINGS:

NEVER TRY TO RUN THE HALO-XRF WITH TWO (OR FOUR!) CR123 BATTERIES. WHILE THEY ARE MECHANICALLY COMPATIBLE, ELECTRICALLY, THEY WILL CAUSE SIGNIFICANT DAMAGE TO THE HALO-XRF.

INSPECT BATTERIES FOR BULGING AND DAMAGE BEFORE USE. IF THE BATTERY SHOWS SIGNS OF BULGING OR DAMAGE, DO NOT USE IT.

DO NOT DAMAGE, PUNCTURE, SHORT CIRCUIT, OR OTHERWISE TAMPER WITH BATTERIES. TURN OFF THE HALO-XRF IF THE BATTERY COMPARTMENT BECOMES TOO HOT. IF POSSIBLE, WAIT UNTIL IT COOLS DOWN BEFORE REMOVING BATTERIES.

ALWAYS REMOVE BATTERIES WHEN STORING OR SHIPPING THE HALO-XRF.

NEVER USE RECHARGEABLE BATTERIES THAT N-VISION OPTICS DOES NOT APPROVE. THE USE OF UNAPPROVED RECHARGEABLE BATTERIES MAY LEAD TO DAMAGE TO HALO-XRF AND PRESENT A SAFETY RISK.

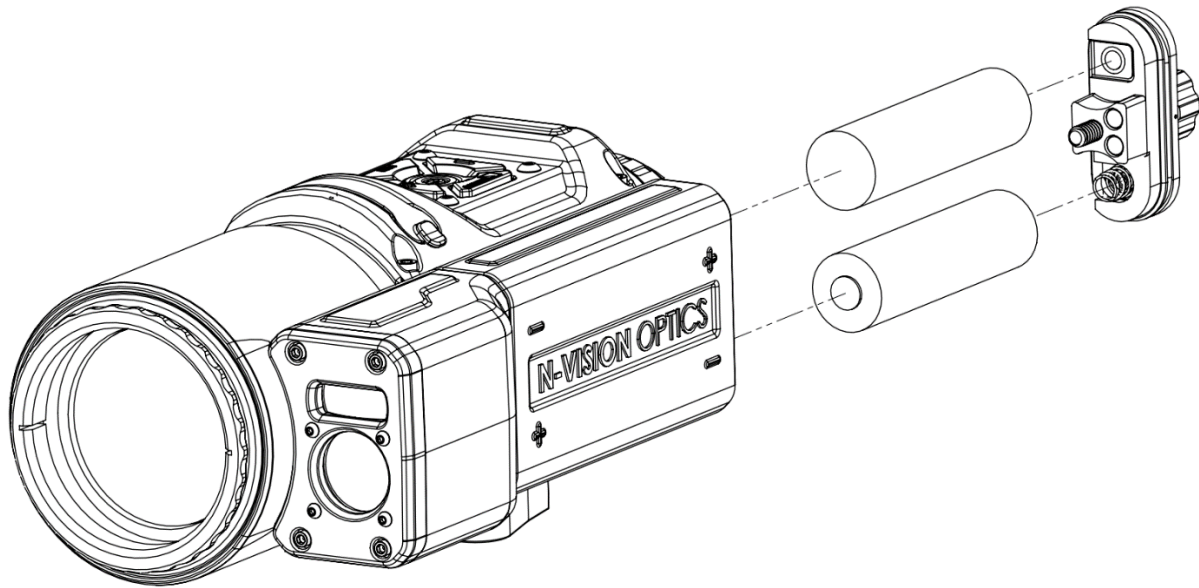

Figure 3. HALO-XRF with Removed Battery Compartment Cover

Unscrew the Battery Compartment Cover (3). Inspect the rubber O-ring outside of the Battery Compartment Cover (3) for damage. Replace and/or lubricate if necessary. Install two 18650 batteries into the Battery Compartment with battery orientation shown on the battery compartment. Close the Battery Compartment Cover (3) with the spring contact being at the bottom and tighten it.

Using External USB Power Source

It is possible to power up the HALO-XRF using electrical power from the computer's USB port or any other USB power source, rated at least 2A (higher is better). The power-up / down procedure is precisely the same as when batteries power the HALO-XRF.

NOTE 1: We recommend keeping the charged batteries in the battery compartment even when an external USB source powers the HALO-XRF. This measure will significantly reduce the possibility of accidental shutdown under the weapon's recoil or unintended disconnect of the USB cable.

NOTE 2: Not all USB battery banks or other USB power sources are created equal. Some may work better and more reliably than others. While N-Vision Optics strives to keep our devices compatible with as many power sources as possible, there is always a possibility that a particular USB power source is not going to be up to the task.

Turning the HALO-XRF On and Off

Press and hold down the Power button (6) for approximately four seconds. When the display in the Ocular (2) lights up, release the Power button (6). To turn the unit off, press and hold the Power button (6) for approximately two seconds until the image in the Ocular (2) disappears.

IMPORTANT: Thermal Calibration

The HALO-XRF requires calibration before each use after powering the unit up, periodically, after a significant change in ambient temperature, when the unit warmed up, and so on. To calibrate the system, cover the objective lens with a lens cover or hand and press and hold the + / CALIBRATION Button (7) for approximately 1.5 seconds.

NOTE: Periodic calibration of the HALO-XRF as it warms up will help achieve the best image quality.

Focusing

The Objective Lens of the HALO-XRF is a fixed focus lens and does not require any adjustments.

Diopter Adjustment

Rotate the Diopter Adjustment Ring of the Eyepiece (2) clockwise or counterclockwise to focus the ocular according to your vision. Details such as reticle and battery level indicator should appear sharp and clear.

Mounting the HALO-XRF on a Weapon

The HALO-XRF comes from the factory with an installed Picatinny (MIL-STD-1913) Compatible Mount. For best results and accuracy, the HALO-XRF must be appropriately mounted on the Picatinny rail. The Picatinny rail needs to be parallel to your weapon's bore to allow maximum elevation and windage adjustments.

Installation Steps:

1. Before attempting to install your HALO-XRF thermal weapon sight, please take the time to ensure that your firearm is **unloaded** and the muzzle pointed in a safe direction.
2. Look at the Picatinny (MIL-STD-1913) Compatible Mount and become familiar with its components.

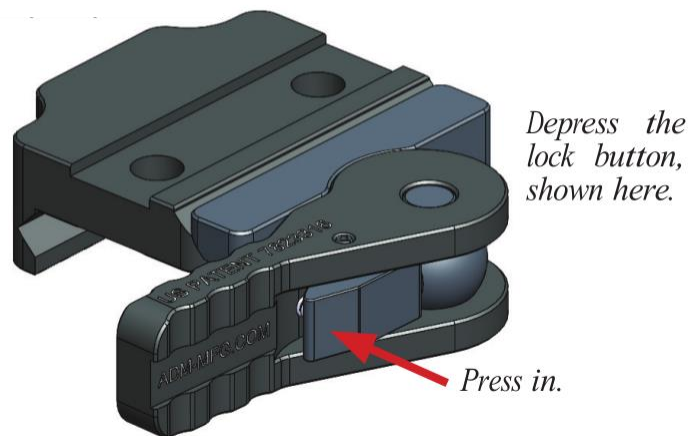

Figure 4. Unlocking Picatinny Mount

3. Unlock the mount. To do this, depress the lock button and swing the lever 180° to the open position.

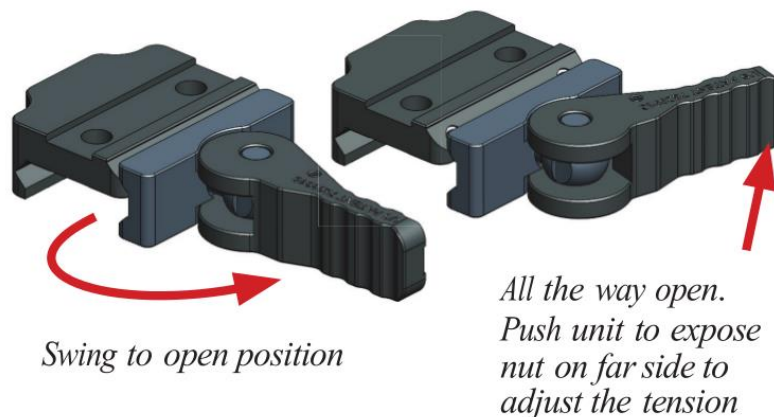

Figure 5. Moving Lever to the Fully Unlocked Position

4. Install the HALO-XRF onto the rail and move the lever to the locked position.
5. Check the tension to close. The correct amount of tension is the maximum amount to apply with one hand to move the lever to a closed position.

NOTE: How much pressure you prefer is dependent on your judgment and personal preference. Please remember, this system has a lot more surface contact than some other mounts, so you may not need to push the lever as hard to achieve the same result.

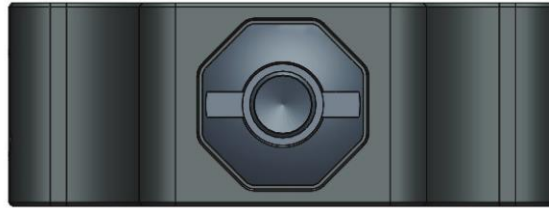

Figure 6. Tension Adjustment Nut

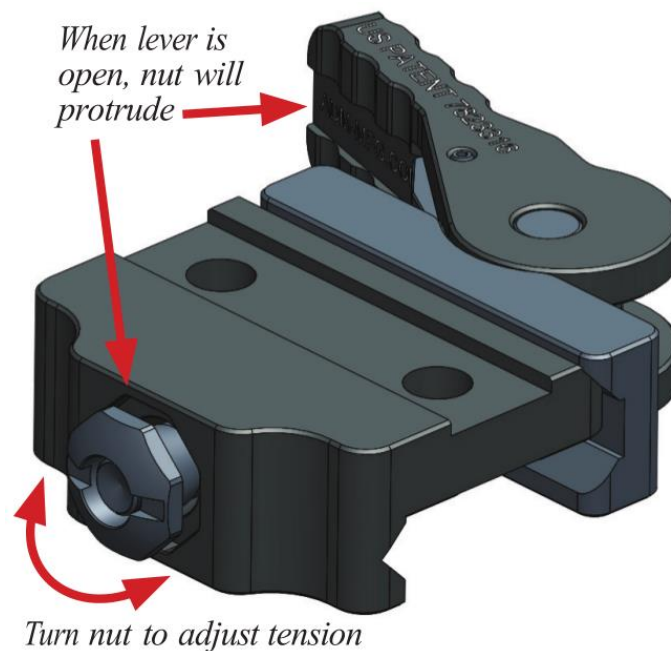

Figure 7. Adjusting Tension of the Mount

6. To adjust the tension, move the lever to the open position and push the lever towards the base. This will make the adjustment nut protrude on the opposite side of the base. With the nut protruding, it may be turned to the right or to the left to make the necessary adjustment. We recommend tightening one to two flats per time, then testing the tension. Since there are eight flats on the octagonal nut, this process may take a few tries to get it where you want it. You will need no tools for this step.

Operating Modes and Menus

The HALO-XRF has the following operating modes:

Normal Mode

Normal Mode is used for observation and aiming with the HALO-XRF. When the user powers up the HALO-XRF, the Normal Mode is the default setting for the system.

Menu Mode

Menu Mode allows the user to conduct system configuration and review some of the system's parameters.

Zeroing Mode

Zeroing mode is used to zero the HALO-XRF to a weapon. Zeroing settings are saved in an energy-independent memory and recalled upon startup of the unit or after changing the reticle Profile under the Reticle Menu.

Image/Video Download Mode

The HALO-XRF will enter the Image/Video Download Mode when “**Connect to PC**” is selected in the Main Menu, and the HALO-XRF is connected to the USB port of a Personal Computer (PC). In this Mode, the HALO-XRF attaches to a PC as an external USB drive. This Mode allows the download and deletion of images and videos from the HALO-XRF memory.

NOTE: Press the Power button (6) to exit from the Image/Video Download Mode.

Software Update Mode

The Software Update Mode allows the user to update the HALO-XRF to the latest version of the software. Software update requires the HALO-XRF Updater software to be installed on the user's PC. The latest HALO-XRF software and the HALO-XRF Updater will be available on the N-Vision Optics website. To enter the Software Update Mode, navigate to Menu -> System and select Update Software. Software update requires the HALO-XRF to have a USB connection to the user's PC (Windows only).

NOTE: The HALO-XRF has to be restarted after the completion of the software update.

HALO-XRF Control Buttons

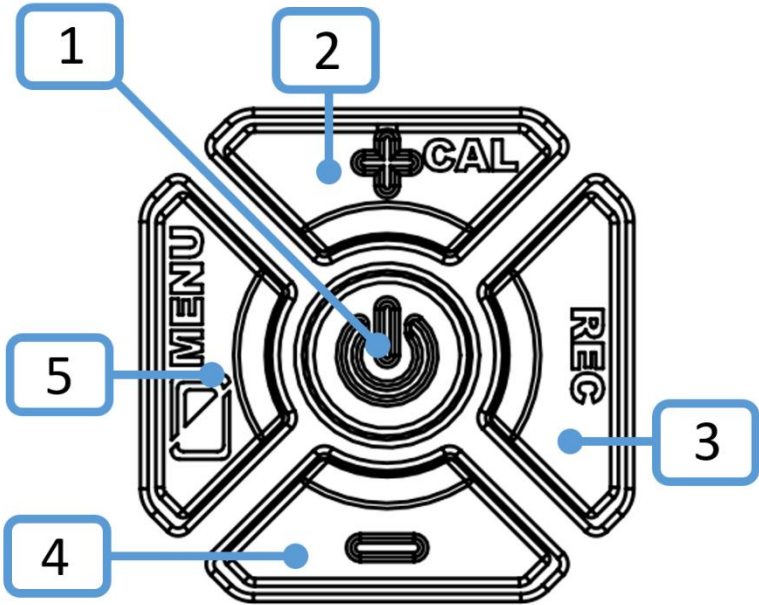

Figure 8. HALO-XRF Control Buttons

Table 2 below provides descriptions of the button functionality in different modes. Refer to Figure 8 above to identify the buttons.

Table 2. The Functionality of Buttons in Different Modes

Normal Mode		
Button	Functions	Description
1	Power / Zoom	<p>Powers the HALO-XRF up if pressed and held for approximately four seconds.</p> <p>Powers the unit down if pressed and held for approximately three seconds.</p> <p>Cycles through the digital zoom settings (1X, 2X, 4X, 8X) if pressed and released quickly.</p>
<p>Note about zoom: By default, all zoom levels are available. However, it is possible to limit zoom values in the Video Settings menu to “No Zoom,” “2X Only”, “2X and 4X”, “2X, 4X, and 8X”, or “4X Only”.</p>		
2	Calibration	Performs calibration if pressed and held for approximately two seconds.
3	Recording	<p>The functionality of this button is defined under the Main Menu -> Camera ->Camera Mode.</p> <p>Camera Mode set to Off: No function.</p>

		<p>Camera Mode set to Photo: Takes a picture if pressed and released quickly.</p> <p>Camera Mode set to Video: Starts video recording if pressed and held for approximately 1.5 seconds. To stop the video recording, press and hold down the button for about 1.5 seconds.</p> <p>Camera Mode set to WiFi Streaming: Starts WiFi streaming if pressed and held for approximately 1.5 seconds. To stop the streaming, press and hold down the button for about 1.5 seconds.</p>
<p>Note about recording: Set Camera Mode to Off to prevent random picture taking or video recording in Normal Mode.</p> <p>Note about WiFi Streaming: WiFi streaming requires some preparations before use. 1. WiFi has to be turned On under Main Menu -> System. 2. Compatible device with WiFi capabilities (mobile phone, computer, tablet) has to be connected via WiFi to the HALO-XRF WiFi network. The network name can be found (and changed) under Main Menu -> System -> Network Name. WiFi password is haloisthebest. WiFi devices connected to the HALO-XRF should have software to receive the Real Time Streaming Protocol (RTSP), for example, VLC. Address for the Network Stream is rtsp://10.254.239.1:8554/x</p>		
4	LRF / Reset to Default Settings	<p>If pressed and released quickly, the functionality of this button is defined under the Main Menu -> LRF.</p> <ol style="list-style-type: none"> 1. LRF is Off. No function. 2. LRF is On, Mode Single. Measures distance once. 3. LRF is On, Mode Scanning. The LRF continuously measures the distance and updates it approximately once per second. To stop measurements, press and release again. <p>Initiates reset of user-configurable settings to default values if pressed and held down for approximately 15 seconds (until the unit shuts off).</p>
<p>Notes about resetting to default values:</p> <ol style="list-style-type: none"> 1. This functionality is beneficial for troubleshooting. Use it if the image does not look right or goes blank. 2. Reset to default values preserves the user's zeroing settings. However, it is always advisable to write down zeroing values and save them for quick recovery in case of accidental change or loss. 		
5	Image Polarity / Menu	<p>Changes image polarity White Hot / Black Hot, Black / White Edge Detect Mode if briefly pressed and released.</p> <p>Enters Menu Mode if pressed and held for approximately two seconds.</p>

Note: Either of the Edge Detection modes can be enabled or disabled in the Video Settings Menu.

Menu Mode		
Button	Function	Description
1	Select / Save	Selects the menu item to move to a submenu or upper-level menu or to make an item changeable. Saves changed menu item. Same as Button 5.
2	Move Up / Change Value	Moves to the next menu item or changes the value of a selected item.
3	Not Used	
4	Move Down / Change Value	Moves to the previous menu item or changes the value of a selected item.
5	Select / Save	Selects the menu item to move to a submenu or upper-level menu or make an item changeable. Saves changed menu item. Same at Button 1.

Zeroing Mode

Note: Zeroing Mode is accessible from Main Menu by selecting Zero.

Button	Function	Description
1	Save and Exit	Pressing the button saves the reticle position and exits to the Normal Mode.
2	Elevation adjustment up	Moves the reticle one step up
3	Windage adjustment right	Moves the reticle one step right
4	Elevation adjustment down	Moves the reticle one step down
5	Windage adjustment left	Moves the reticle one step left













NOTE:

Pressing and holding down any button 2, 3, 4, or 5 for more than two seconds will enter reticle movement into Rough Adjustment Mode. In Rough Adjustment Mode, the reticle moves in 5 pixels steps as long as the control button is pressed. The release of the control button immediately ends the Rough Adjustment Mode.

HALO-XRF Screen Icons

Table 3 below provides descriptions of icons that can be present in the Normal Mode.

Table 3. HALO-XRF Icons

Icon	Description
	Digital zoom set to 2x
	Digital zoom set to 4x
	Digital zoom set to 8x
	Battery level indicator
	Camera Mode set to Photo
	Camera Mode set to Video
	Video recording is in progress
	Camera Mode set to WiFi Streaming
	WiFi video streaming is in progress
	WiFi is on
	LRF Single Measurement Enabled
	LRF Scanning Mode Enabled

Normal Mode Description

Normal Mode is used for observation and aiming with the HALO-XRF. When the user powers up the HALO-XRF, it always starts in Normal Mode. For controls available in Normal Mode, see Table 2 above.

The following functions are supported in the Normal Mode:

Taking Photos / Video Recording / Video Streaming

Camera Mode selected under the Main Menu -> Camera -> Camera Mode determines what if anything can be captured (Photo or Video) or if the video streaming may be initiated.

Camera Mode set to **Off**: Recording Button (3) is disabled.

Camera Mode set to **Photo**: Pressing and quickly releasing Button (3) (**Recording**) captures the image and saves it in the HALO-XRF memory.

Camera Mode set to **Video**: Pressing and holding the Button (3) (**Recording**) for approximately 1.5 seconds will start the video recording. To stop the video recording, press and hold down the Button (3) (**Recording**) for about 1.5 seconds.

Camera Mode set to **WiFi Streaming**: Pressing and holding the Button (3) (**Recording**) for approximately 1.5 seconds will start the WiFi streaming. To stop the streaming, press and hold the button for about 1.5 seconds.

NOTE: Photo, Video and WiFi Streaming are turned off by default. Each can be enabled under the Main Menu -> Camera -> Camera Mode.

Saved pictures and videos can be downloaded later to a PC using the USB cable or the WiFi connection.

Selecting Polarity

Pressing and releasing the Button (5) (**Polarity/Menu**) cycles through Black Hot, White Hot, Black Edge Detect, and White Edge Detect modes (in sequence). Black Hot Mode displays the heat sources as black. The cooler objects are displayed as increasingly lighter shades of gray, while the coldest objects are white. White Hot Mode displays the heat sources as white. The cooler objects are displayed as darker shades of gray, while the coldest objects are black.

NOTE: If preferred, Edge Detect modes can be turned on and off under Video Settings Menu in Menu Mode.

Edge Detect mode darkens or lightens areas of the image that are algorithmically not important and outlines objects that produce a distinctive heat signature. This helps users stay focused for extended periods and quickly identify the object of interest when it becomes visible.

Digital Zoom

The HALO-XRF features digital zoom. Zoom is activated by pressing on the Button (1) (**Power / Zoom**). It is used to magnify the central area of the output image. The zoom sequence allows the user to select one of the zoom factors. When the system is turned on, the sight will display images without any digital magnification. By default, when the Button (1) (**Power / Zoom**) is pressed and released, the sight will sequence through 2X, 4X, and 8X, then return to 1X. The indicator in the upper left corner of the display shows the current digital zoom setting.

NOTE: It is possible to limit zoom values in the System Settings menu to “No Zoom,” “2X Only”, “2X and 4X”, “2X, 4X, and 8X”, or “4X Only”.

LRF

The HALO-XRF features the integrated Laser Rangefinder (LRF). The LRF is activated by pressing the Button (4) (-). For the LRF to function, it has to be turned on under Main Menu -> LRF. When the LRF is on, the icon showing its mode (Single or Scanning) shows up on top of the screen. To use the LRF, aim the LRF reticle (square box) at the object of interest and press the Button (4) (-) if in the Single mode. Alternatively, if the Scanning mode is selected in the LRF menu, activate the LRF by pressing the Button (4) (-) and when ready, aim the LRF reticle (square box) at the object of interest. The LRF functionality is only available in the Normal Mode and not in the Menu Mode or Zeroing Mode. The LRF measurement can be performed in yards or meters. Units of measurements can be selected under the LRF menu.

NOTE 1: The size of the LRF reticle depends on the zoom level. At higher zoom levels, the LRF “spot” is larger, which is reflected in the increased size of the LRF reticle.

NOTE 2: The position of the LRF reticle is pre-set at the factory and cannot be changed by the user. Depending on the scope’s zero, the LRF reticle may or may not be visible at higher zoom levels, for example, at 8x.

NOTE 3: The HALO-XRF LRF performance may be affected by ambient conditions and the reflectivity of the target being ranged. Factors such as rain, fog, or bright light will have a negative impact on its ability to perform accurate measurements. In case of the measurement failing, the --- will be displayed instead of an accurate numerical reading.

Reset to Factory Settings

Pressing down and holding the Button (4) (-) for approximately 15 seconds restores the HALO-XRF to factory settings and parameters. Button (4) (-) has to be held down until the HALO-XRF turns off. This operation may be helpful if the HALO-XRF demonstrates an unexpected behavior, the image is not clear, or its response is sluggish, etc.

NOTE: Reset to Factory Settings preserves Zeroing information, but it is always prudent to write down and save zeroing numbers for fast recovery in an unlikely memory corruption event.

Menu Mode Description

Menu Mode allows the user to conduct system configuration (choice of a reticle, zeroing, brightness, etc.), review some of the system’s parameters, choose the image capture mode, configure WiFi, etc. To enter the Menu Mode, press and hold Button (5) (**POLARITY / MENU**) for approximately three seconds.

NOTE: Menu fonts may be hard to read in Edge Detect mode. If it causes problems, enter Menu Mode while in Black Hot or White Hot mode.

Navigation in Menu Mode

To **move up** between menu items, press Button (2) (**+ / CAL**).

To **move down** between menu items, press Button (4) (-).

NOTE: The indicator on the left of a menu item shows which menu item is current.

Selecting a menu item: press Button (4) (**IMAGE POLARITY / MENU**) or the Button (1) (**POWER / ZOOM**). Selecting a menu item makes it possible to change its value or leads to an immediate transition to the upper or lower-level menu.

NOTE: The indicator on the left of a menu item changes shape when an option is selected. When the indicator changed its shape, the corresponding setting can be changed.

Changing a menu item (if changeable): Use Button (2) to increase the value or Button (4) to decrease it.

To save the changed menu item, press the Button (1) (**POWER / ZOOM**) or the Button (5) (**IMAGE POLARITY / MENU**).

Main Menu

Main Menu contains the following choices:

Display Menu

This submenu allows the user to

- Change display brightness
- Set contrast enhancement (CE) level
- Choose image sharpness (recommended value is 2)
- Select gamma setting for the display.

System Settings Menu

Under this submenu, a user can

- Turn WiFi on or off
- Choose a WiFi network name
- Select the most appropriate Region of Interest (ROI)
- Configure available Digital Zoom settings
- Configure available Edge Detection modes
- Reset Settings; same as holding down the Button (4) for 15 seconds
- Put the HALO-XRF into the Software Update mode.

Reticle Menu

The Reticle Menu allows the user

- To turn the reticle on or off (Show Reticle)
- Select the reticle Profile
- Choose the reticle type
- Configure the adaptive color for the reticle.

Camera Menu

Under this menu, a user can choose the Camera Mode (Off, Photo, Video, WiFi Streaming) and free up the media storage space by deleting all files.

Connect to PC

Selecting this item allows connecting the HALO-XRF to a PC with a USB cable and downloading videos and photos from the HALO-XRF to the PC.

LRF

Under the LRF menu, the user can turn the LRF module on or off, select the LRF operating mode (Single or Scanning), and choose units of measure (meters or yards).

Zero Menu

When Zero Menu is selected, the HALO-XRF is entering the Zeroing Mode. In this Mode, the user can adjust the reticle position for the reticle profile chosen in the Reticle Menu.

Save and Exit

Selecting Save and Exit in the Main Menu brings the user back to the Normal Mode.

Display Menu

Brightness

It is used to adjust the display brightness between 1 and 8. The recommended setting is 5.

CE Level

Changes Contrast Enhancement Level between 0 and 6. The recommended setting is 1.

NOTE 1: Change of the CE Level allows the user to increase or decrease algorithmic contrast adjustment of the image. CE Level adjustment changes parameters in a complicated gain and contrast adjustment logic tailored to make object(s) of interest appear as clear as possible. Increasing CE helps to distinguish fine image details in low thermal contrast conditions, but setting the value too high will lead to a grainy image.

NOTE 2: The contrast enhancement level represents a tradeoff between image dynamic range and contrast. A higher enhancement level makes smaller emittance differences more discernable but reduces the visible dynamic range. Setting the CE level too high may lead to grainy looking image.

NOTE 3: Different CE Adjustment settings may be required for different observation conditions.

NOTE 4: CE Adjustment can be required when switching between radically different scenes, reversing the image's polarity, etc.

Sharpness

Changes image Sharpness between 0 and 4. The recommended setting is 2.

NOTE: Live imagery can be enhanced by either sharpening or introducing slight blurring. **0:** Introduces slight imagery blurring. **1:** Leaves imagery as is. **2 – 4:** Introduces a progressive level of sharpening. Setting the Sharpness level too high may lead to grainy looking image.

Gamma

This setting is changing the Gamma curve for the display. Available values and between 0 and 2. The recommended setting is 1.

NOTE: changing the Gamma setting visually changes the brightness of the display and alters the way the image is presented on the black and white screen. The adjustment may be most effective if done in combination with an adjustment of brightness.

Save and Exit

Selecting Save and Exit in Video Settings Menu brings the user back to the Main Menu.

System Settings Menu

WiFi

Turns WiFi On or Off. The default setting is Off.

NOTE 1: WiFi connection to the HALO-XRF can be used to stream live imagery, download and / or delete pictures and videos from the HALO-XRF memory.

NOTE 2: When the WiFi is on, it dramatically increases HALO-XRF power consumption and reduces battery life. Keep WiFi off when it is not in use. WiFi is off after restarting the HALO-XRF and needs to be manually turned on if needed.

NOTE 3: WiFi password is “**haloisthebest**” (no quotation marks). It cannot be changed.

Network Name

Network Name defines the WiFi SSID. Options here are HALO-XRF, N-Vision, and Thermal. Changing the Network Name is only necessary when there are a few HALO-XRF near each other, and they all require WiFi connections.

ROI (Region of Interest)

Selects the appropriate Region of Interest (ROI). For scanning, it is recommended to set ROI to Full. ROI $\frac{1}{2}$ and ROI $\frac{1}{4}$ lead to the optimization of the image based, correspondingly, on the $\frac{1}{2}$ or $\frac{1}{4}$ central part of the image. It makes the image closer to the center look better, but the peripheral parts of the image may suffer.

Digital Zoom

This setting allows the user to choose Digital Zoom levels included in the rotation when switching the Zoom with Button (1) in the Normal Mode. Options are "No Zoom", "2X Only", "2X and 4X", "2X, 4X, and 8X", or "4X Only".

Edge Detection

This setting allows the user to choose which of the Edge Detect modes (Black Edge, White Edge, or neither) is included in the rotation when switching Polarity with Button (5) (**POLARITY / MENU**) in the Normal Mode.

NOTE: In Edge Detection mode, the HALO-XRF outlines regions of the image with similar infrared emittance named “edge.”

Reset Settings

Choosing this option allows the user to reset the HALO-XRF parameters (both user-configurable and not user-configurable) to factory default values. After selecting Reset Settings, there is a confirmation dialog that protects the user from unintended reset. The Reset takes a few seconds to complete. The HALO-XRF shuts down after the successful reset.

NOTES:

1. This functionality is beneficial for troubleshooting. Use it if the image does not look right or goes blank.
2. Reset to default values preserves the user's zeroing settings. However, it is always advisable to write down zeroing values and save them for quick recovery in case of accidental change or loss.

Update Software

There may be occasional software updates for the HALO-XRF. To enter the software mode, select the Update Software and choose Yes in the confirmation dialogue.

NOTES:

1. Software update requires the user to download HALO-XRF update software from the N-Vision Optics website and install it on Windows PC. Installation instructions are provided with the software.
2. **Important:** HALO-XRF has to be powered by sufficiently charged **batteries** and **NOT** connected to the PC with a USB cable before selecting Update Software. USB cable from the HALO-XRF can be connected to the user's PC only after selection Yes in the Software Update confirmation dialogue.
3. The HALO-XRF update software can be used after connecting the HALO-XRF to a PC.
4. Follow instructions for the HALO-XRF update software to perform the update. HALO-XRF will be powered off after the completion of the update.
5. **Important:** After the HALO-XRF has been powered off at the end of the update, disconnect it from the PC and restart using **batteries**. **DO NOT** restart the HALO-XRF while it is still connected to a PC with a USB cable.

Save and Exit

Selecting Save and Exit in Settings Menu brings the user back to the Main Menu.

Reticle Menu

The Reticle Menu contains the following choices:

Show Reticle

Allows turning the reticle on or off.

Profile

Users can save up to four reticle positions by selecting one of the Profiles. Each Profile is saved with its Reticle Type and zeroing information. This functionality allows, for example, zero the HALO-XRF on multiple weapons (up to 4) using different Profiles and move it in the future between weapons without a need to re-zero by merely selecting the appropriate Profile.

Reticle Type

There are eight user-selectable reticles numbered 1 to 8. When selected, a visual representation of each reticle is displayed instead of the previous one.

Adaptive Color

NOTE: The adaptive color setting allows the reticle's color (white or black) to be dependent upon the color of the displayed imagery. For example, if the reticle overlaid over an image is white and imagery under the reticle ends up white, the reticle would become invisible unless the Adaptive Color is turned on.

Adaptive Color settings allow the user to turn off the Adaptive Color functionality or configure the Adaptive Color algorithm's sensitivity level. Available options are Low, Medium, and High.

Save and Exit

Selecting Save and Exit in Reticle Menu brings the user back to the Main Menu.

Camera Menu

Camera Mode

Choosing the desired Camera Mode allows the user to select between Photo, Video, or WiFi Streaming modes or turn the camera off to prevent an accidental picture or video recording. When the camera is on, an icon in the upper left corner of the screen indicates the selected mode.

NOTE 1: WiFi Streaming mode does not allow the user to save photos or videos on the HALO-XRF, but it enables transmission of the video stream to a receiving device connected to the HALO-XRF WiFi network. Video streaming starts and stops when the RECording Button (3) is pressed and held down for approximately 1.5 seconds.

NOTE 2: In addition to the WiFi connection to the HALO-XRF, the WiFi Streaming requires an appropriate application on the user's PC or a mobile device. Video is transmitted using the Real Time Streaming Protocol (RTSP). Several free and paid applications for every imaginable platform are supporting RTSP streaming. We recommend VLC. It's widely available and appears to be relatively stable. Use URL <rtsp://10.254.239.1:8554/x> in VLC under Open Network Stream or in any other RTSP streaming application to connect to the video stream from the HALO-XRF.

NOTE 3: as of the time of writing this Manual, VLC has a known RTSP buffering problem, leading to approximately two seconds processing delay. Additionally, it has been reported that occasionally the RTSP stream can get frozen after extended use. The VLC may have to be restarted to address the later issue.

Delete All Files

Allows deletion of ALL files saved on the HALO-XRF to free up internal storage space. This action is not reversible, and once deleted, the files cannot be recovered. Use the USB connection to a PC or WiFi connection if you want to keep some of the files.

Save and Exit

Selecting Save and Exit in the Camera Menu brings the user back to the Main Menu.

Connect to PC

Selecting this item allows connecting the HALO-XRF to a PC with a USB cable and downloading videos and photos from the HALO-XRF to the PC. Additionally, files in the internal HALO-XRF memory can be deleted or renamed. Make sure that batteries power the HALO-XRF before connecting to a PC.

IMPORTANT 1: to disconnect the HALO-XRF from a PC, eject it from the PC as an external drive and press the Power / Zoom Button (1).

NOTE 1: HALO-XRF supports the USB connection to PCs running Windows, Mac OS X, and Linux operating systems.

NOTE 2: Select Connect to PC before connecting the USB cable to a PC.

LRF

Selecting LRF from the Main Menu brings the HALO-XRF to the LRF Menu. The LRF Menu has the following choices:

LRF

This option permits switching the LRF module On or Off. If the LRF is On, the distance measurements can be performed in the Normal Mode. If the LRF is Off, the LRF functionality is fully disabled.

NOTE: It is beneficial to keep the LRF Off when not intending to use it to preserve the battery life.

Mode

Allows selection of Single or Scanning Mode for the LRF. If the Single Mode is selected, the LRF, when the Button (4) (-) is pressed, will perform a single measurement and stop until the Button (4) (-) is pressed again. The result of the last measurement will be displayed in the right top corner of the screen. If the Mode is set to Scanning, the LRF will continuously measure the distance after the Button (4) (-) is pressed until it is pressed again.

Units

This menu item permits the selection of between Yards and Meters for the LRF measurements.

Save and Exit

Selecting Save and Exit in the LRF Menu brings the user back to the Main Menu.

Zero

Selecting Zero from the Main Menu brings the HALO-XRF to the Zeroing Mode, allowing zeroing of the sight.

Zeroing Mode Description

Use Zeroing Mode to zero the HALO-XRF according to the procedure described below.

Zeroing Procedure

NOTES:

1. Zeroing can be done at any digital zoom. The zoom that will be used for zeroing has to be selected before entering the Menu Mode. Change of zoom in the Menu Mode or Zeroing Mode is not possible. The precision of the reticle movement increases for higher zoom levels. At lower zooms, the reticle position is rounded up/down to the nearest available position.
2. Zeroing of thermal scopes is different from zeroing a regular day-time scope. During zeroing, the reticle should move to the Point of Impact (POI).

Zeroing of the HALO-XRF is achieved by performing the following steps:

1. Make sure the weapon sight is securely mounted on your weapon.
2. Fix a thermal target, for example, at 25 meters distance.
3. Turn on the HALO-XRF.
4. Perform Calibration.
5. Ensure that the target is visible with good contrast through the HALO-XRF before continuing.
6. Use the digital zoom if it helps you to see the target clearer or you want to increase the precision of your zero.
7. If necessary, adjust settings in the Display Menu and System Menu to ensure the best possible view of the target.
8. In the Reticle Menu, select the Profile and Reticle Type.
9. Enter Zeroing Mode by choosing Zero in the Main Menu.
10. Use the reticle's center to aim the weapon at the target and fire 3-5 rounds.
11. After clearing the weapon, visually check the center of the shot group on the target.
12. Make adjustments as necessary to the windage and elevation.
 - a. Buttons (3) and (5) provide movement of the reticle in the horizontal direction (windage adjustment). Button (3) moves the reticle right, Button (5) moves the reticle left.
 - b. Buttons (2) and (4) provide movement of the reticle in the vertical direction (elevation adjustment). Button (2) moves the reticle up, Button (4) moves the reticle down.
 - c. There is an arrow pointing up or down in the bottom left corner of the display and a number next to it. The arrow's direction shows the direction that the reticle

- moved relative to the center of the display and the number of steps made in this direction. For example, ↑7 in the left bottom corner of the display means that the reticle is located 7 pixels above the display center.
- d. There is an arrow pointing left or right in the bottom right corner of the display and a number next to it. The arrow's direction shows the direction that the reticle moved relative to the center of the display and the number of steps made in this direction. For example, ←3 in the right bottom corner of the display means that the reticle is now located 3 pixels to the left from the center of the display.
 - e. If the counter in the bottom left or right corner reads 00 it means that the reticle is located in the middle of the display in the vertical or horizontal direction (or both if both counters are at 00).
 - f. To move the reticle in regular small steps (1 pixel per step), the corresponding Button has to be pressed and released within 0.4 seconds. Pressing and holding a Button down for more than 2 seconds will enter the reticle movement into the Rough Adjustment mode. In the Rough Adjustment mode, the reticle moves in 5-pixel increments as long as the Button is pressed. Release of the Button will immediately end the Rough Adjustment mode.
13. Fire and adjust the reticle until the center of the shot grouping and the reticle converge.
 14. Exit from Zeroing Mode by pressing the Button (1) (Power / Zoom).

TH Zero

With HALO-XRF thermal scopes, it is possible to use the “one-shot” zeroing procedure widely known as TH Zero. The TH Zero requires careful aiming at a target and placing one or more (typically three) accurate shots. If the POI is not visible on the target, the shooter may put something relatively warm or cold at the POI (aluminum foil, warm spent cartridge, etc.) When the Point of Aim (POA) and POI are clearly visible through the HALO-XRF, the user should aim at the original POA and perform the HALO-XRF calibration without covering the objective lens. After that, the target's image showing the reticle, POA, and POI will stay “imprinted” on display. To complete the TH Zero, the user needs to cover the objective lens with a lens cup, enter Zeroing Mode, and move the reticle to the POI. After exiting from the Zeroing Mode and performing calibration with a closed objective lens, the HALO-XRF should be perfectly zeroed and ready to go.

WiFi Download / Deletion of Files

The HALO-XRF allows the user to download and delete video and photo files using the WiFi connection. File download and deletion require the following steps:

1. Turn on the WiFi (Main Menu -> System Menu -> WiFi On. Notice the selected Network Name under the System Menu.
2. Connect your device (mobile phone, tablet, computer) to the HALO-XRF WiFi that will show up on your device as a Network Name you noticed in #1. The network password is “**haloisthebest**”.
3. Launch browser on your device. In the address field, enter **10.254.239.1** and hit Go or Enter. You may consider creating a bookmark to avoid re-entering this address in the future.

4. If there are any photos or videos saved on your HALO-XRF, you'll see corresponding folders. When you navigate to them, you can select a file or files that you for downloading or deletion.
5. Hit a corresponding delete or download button. After the confirmation dialog, your file or files will be downloaded or deleted.
6. If you download a single file, it will be saved on your device as a .jpg (photo) or .mp4 (video) file. However, if you choose to download multiple files, they will be saved as a ZIP archive that has to be unzipped before you can see your files.
7. The location where the downloaded files are saved on your device depends on the type of device. Apple iOS saves it in **Files**. You may be required to install a free Apple **Files** application to ensure that everything works as expected. If you use Safari as a browser on iPhone or iPad, you can configure it to either save downloaded files on your phone or iCloud Drive. Other browsers provide you with different options for file download locations.
8. The unzipping procedure is device-specific. On Apple mobile devices, you have to click on the archive found in Files, and it will be automatically unzipped. The unzipping process under other operating systems should be similarly simple. Refer to your device (phone, tablet, PC) instructions for details.

Maintenance Instructions

Introduction

The HALO-XRF is designed to be used in diverse environments and rugged conditions. It is recommended that regular and simple maintenance be performed for optimal system performance.

Preparing for Maintenance

Before performing any maintenance or cleaning of the system, remove all power sources from the HALO-XRF, including batteries and, if connected, an external USB power supply.

Cleaning the HALO-XRF

When necessary, use a moistened clean cloth to wipe the outside of the unit, EXCEPT FOR THE OPTICAL SURFACES. Be sure to wipe away excess dirt and dust that may restrict the performance or damage moving and mating parts. If needed, the use of a highly diluted detergent solution is permissible. Dry with a soft clean cloth, or allow the HALO-XRF to air-dry before storing it.

Cleaning the Optics

When cleaning the lens is required, first blow any loose dirt or grit away from the lens's surface. Use the supplied lens cleaning paper, lightly moistened with water or lens cleaning fluid, and lightly wipe the optical surfaces using a circular motion. Discard each lens cleaning paper after one use to avoid transferring grit or foreign matter onto the lens surface. If the lens remains dirty, use a cotton swab lightly moistened with lens cleaning fluid to remove the foreign matter from the lens. Dry with clean, unused lens cleaning paper.

Checking for Damage and Corrosion

As a general guideline, inspect the HALO-XRF, accessories, and the case after every use. Look for heavy wear and cracks in rubber or plastic. Inspect for moisture or corrosion in the battery compartment. Check for scratches, condensation, and foreign matter on optical surfaces.

Electrical Interface

The HALO-XRF is equipped with a waterproof USB-C type connector located towards the objective lens. A rubber push-in dust cup covers it. The purpose of this connector is to provide the user with the ability to:

- Power the HALO-XRF from an external USB power source.
- Download images and videos from the HALO-XRF to a PC and / or delete or rename them.
- Update HALO-XRF software.

Troubleshooting

Refer to Table 4 below for troubleshooting instructions for the most common problems. If the equipment malfunction is not listed or actions listed do not correct the fault, notify your maintainer.

Table 4. Troubleshooting Instructions

Malfunction	Test or Inspection	Corrective Action
Unit fails to turn ON.	Visually inspect. Check for defective, missing, or improperly installed batteries.	Inspect Battery Compartment for damage. Replace batteries or install them correctly. Tighten the Battery Compartment Cover.
The HALO-XRF shuts down under recoil.	Verify that the Battery Compartment Cover is tight. If using an external USB battery pack, verify a reliable USB cable connection and inspect the cable for visible damage.	Tighten the Battery Compartment Cover. Replace batteries if necessary. NOTE: Have charged batteries in the Battery Compartment when using an external USB power source.
The HALO-XRF is ON, but there is no thermal image on the display	Visually inspect. Check if the Lens Cover is on or something else obstructs the field of view.	Remove Lens Cover or other obstruction.
Poor image quality.	Visually inspect. Check for fogging or dirt on the Objective Lens or Ocular.	Clean optics. See the maintenance section of this manual. Cover objective lens and perform thermal calibration.

		<p>Verify that the eyepiece is correctly focused.</p> <p>Adjust settings under the Display and System Settings Menus to achieve the best possible image.</p>
The diopter adjustment is very hard to turn or grinding.	Visually inspect. Check for dirt or debris on Ocular.	Carefully remove the rubber Eye Cup. Clean with a soft dry cloth.
The HALO-XRF will not zero or loses zero.	<p>Check to see if the HALO-XRF is securely fastened to the Weapon Mount.</p> <p>Check to see that the Weapon Mount is correctly and securely fastened to the weapon.</p>	Tighten the weapon mount to the HALO-XRF. The recommended torque is 20 in-lb. Correctly and securely fasten weapon mount to a weapon.
WiFi connection does not work	Verify that there are no other devices connected to the HALO-XRF	Try to re-connect to the HALO-XRF WiFi. Turn your device's WiFi off and on.

This page is intentionally left blank